

Documenting designs in 3D

SIEMENS

White Paper

With new standards for 3D product definition, CAD models legitimately join 2D drawings as a fully sanctioned means of conveying product and manufacturing information. Siemens PLM Software has been instrumental in defining the standards for 3D product definition, and delivers software tools that make it possible to document 3D designs in compliance with the new standard. The new 3D annotation capability enables significant process improvements.



Contents

- Siemens leads the evolution to 3D product definition3
- ASME validates 3D annotation.....4
- Siemens supports 3D product definition5
- 3D product definition improves productivity6
- Conclusion7

ASME validates 3D annotation

Work began on ASME Y14.41 in 1997. At that time many designers were already annotating solid models with information needed for manufacturing, such as dimensions, tolerances, assembly notes and so on, but each did so in a proprietary way and the industry lacked a common method. Without a common and recognized standard, most companies continued to convey and maintain manufacturing information through 2D drawings.

Drawings cost time and money, and can represent a substantial overhead in new design projects, especially for the intricate models required for consumer products or the large and complex assemblies common in the machinery industry. Drawings rarely escape further modification as the product evolves, introducing a more pressing problem of how to keep drawings and solid models in sync after design changes are made. Recognizing this, ASME formed a committee to extend its standards for 2D drawings (ASME Y14.5M) into the 3D world. The committee wrote, "3D modeling is the future of design, and ASME Y14.41 sets the rules."

Siemens has been a member of the Y14.41 committee since its inception and has played a key role in helping define the new standard. Our commitment is unmatched in the software industry.

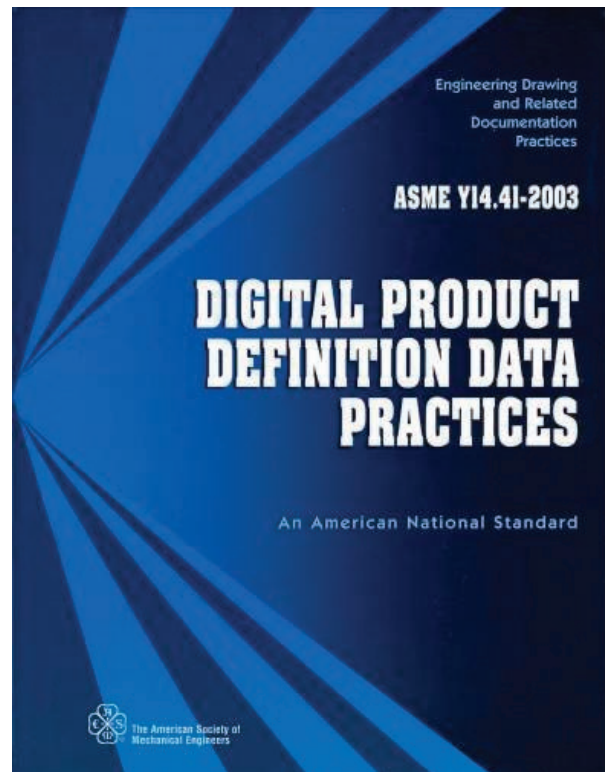

Siemens supports 3D product definition

ASME Y14.41 calls for certain capabilities within the design system. Because Siemens worked closely with ASME on the creation of the new standard, we have been able to ensure that our NX™ software solution for digital product development delivers the functionality needed to produce 3D annotated designs that are in full compliance with the standard. As recognition of ASME Y14.41 grows in the marketplace, it is common for people to ask “Can your software produce models that are in compliance with the new standard?” We are proud to be able to reply, “Yes. Absolutely.”

NX includes well established capabilities for 3D annotation, and Siemens’ customers worldwide are actively utilizing and endorsing 3D annotation on their solid model designs. Supporting all the major concepts and requirements defined in ASME Y14.41, this comprehensive list of capabilities in NX 5 provides the most complete collection of tools offered within a CAD product to date, and further enhancements are being developed.

NX 5 collects these capabilities under a menu selection that contains all the tools necessary for making 3D models the master repository for all product and manufacturing data. The PMI toolbar provides a single, unified interface for creating, editing and querying PMI on the solid design. In addition to facilitating the creation of 3D product definitions, this tool will check models for compliance with the ASME standard, offering the options of stringent and relaxed compliance levels.

Designers attach 3D annotation directly to the model by associating it with the appropriate portions of the geometry to indicate design intent. The plane in which the annotation is created is under the user’s

control and is used to facilitate placement of the annotation by defining its reading direction. Model Views (equating to Saved Views in ASME Y14.41) can be used to manage the annotation on a model by organizing it into sets of information relevant to a specific orientation of the model or a particular application for the model. The NX Part Navigator organizes PMI annotation into a convenient location for viewing and interrogating its associativity to the model geometry.

Of course, Siemens recognizes the ongoing need to create and maintain 2D drawings. The annotation placed on the 3D model can be leveraged to create accurate, production-ready and fully associative detailed drawings with not much more than a single click of the mouse.

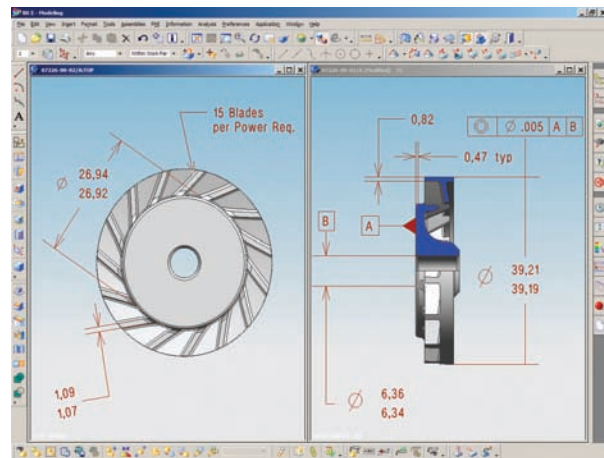

3D product definition improves productivity

When solid models become the repository for PMI, a company has a true “master model” approach. Instead of having solid models for defining product geometry and drawings for conveying production information, there is a single digital representation (the annotated 3D solid model) that documents everything about the product. This 3D information is always accurate, always up to date and can even become “invalid” under certain conditions, alerting the user to take action and preventing costly downstream problems. This also eliminates the difficulty of keeping multiple product representations in sync and opens the door to a more efficient way of creating and documenting products.

As engineers and designers add more PMI to the solid model during creation, these master models become increasingly “smarter,” going far beyond a geometrical representation to explicitly embed design intent and eliminate the risks introduced from a reliance on human inference as the models are leveraged in all downstream processes. In fact, this is the primary vision of PMI. Create it once, use anywhere.

For example, 3D annotation embedded in a model can be imported into analysis and CAM applications, sent to suppliers and used on the shop floor – just as drawings would have been used in the past. But these models, because they are 3D, are much easier to visualize and understand. There is no need to mentally reconstruct the model from 2D representations and it is easier to query the original design intent, both of which mean improved communication

from the start and a higher probability of the right product, right the first time.

Inexpensive and intuitive viewing applications, such as XpresReview, make master models accessible to the broad base of people throughout the extended enterprise and supply chain who don't use CAD. And because the PMI is integrated and associated with the 3D model, the PMI content can be directly leveraged in digital applications such as tolerance analysis and machine toolpath generation, without the need to re-enter the data. In situations where drawings are still required, such as in work for government organizations, 2D views can be spun off the master model in minutes.

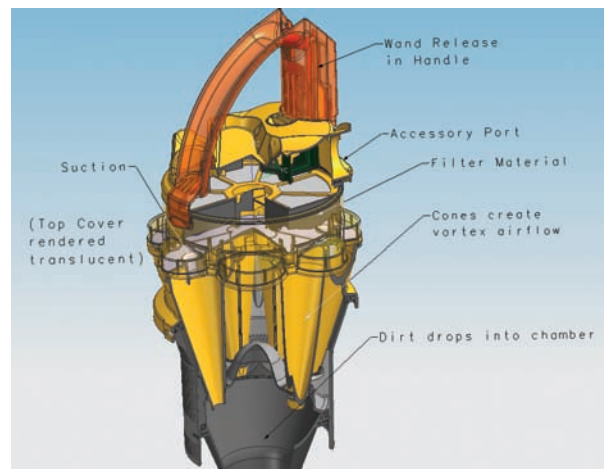

Conclusion

The work we've done so far at Siemens PLM Software is just the start. We'll continue to enhance our software to support ASME Y14.41 as it evolves, and as your processes evolve in turn. Siemens believes that 3D product definition represents the future, and that 3D master models will eventually become the predominant way of documenting and conveying product data. We'll do what we need to do to make sure your company benefits from the evolution to 3D product definition.

About Siemens PLM Software

Siemens PLM Software, a business unit of the Siemens Industry Automation Division, is a leading global provider of product lifecycle management (PLM) software and services with 6.7 million licensed seats and more than 69,500 customers worldwide. Headquartered in Plano, Texas, Siemens PLM Software works collaboratively with companies to deliver open solutions that help them turn more ideas into successful products. For more information on Siemens PLM Software products and services, visit www.siemens.com/plm.

www.siemens.com/plm

All rights reserved. Siemens and the Siemens logo are registered trademarks of Siemens AG. D-Cubed, Femap, Geolus, GO PLM, I-deas, Insight, JT, NX, Parasolid, Solid Edge, Teamcenter, Tecnomatix and Velocity Series are trademarks or registered trademarks of Siemens Product Lifecycle Management Software Inc. or its subsidiaries in the United States and in other countries. All other logos, trademarks, registered trademarks or service marks used herein are the property of their respective holders.

© 2011 Siemens Product Lifecycle Management Software Inc.

X4 6139 7/11 C

The logo for Acuity, featuring the word "ACUITY" in a stylized, blue, sans-serif font with a white outline. The letters are slightly shadowed to give a 3D effect.

Your engineering technology partner

www.acuityinc.com ■ info@acuityinc.com

Main Office: 7320 SW Hunziker Street, Suite 205 Tigard, OR 97223

Toll-free: 888.747.0850 ■ Direct: 503.747.0850 ■ Fax: 503.747.4269

Siemens Industry Software

Headquarters

Granite Park One
5800 Granite Parkway
Suite 600
Plano, TX 75024
USA
1 972 987 3000
Fax 1 972 987 3398

Americas

Granite Park One
5800 Granite Parkway
Suite 600
Plano, TX 75024
USA
1 800 498 5351
Fax 1 972 987 3398

Europe

3 Knoll Road
Camberley
Surrey GU15 3SY
United Kingdom
+44 (0) 1276 702000
Fax +44 (0) 1276 702130

Asia-Pacific

Suites 6804-8, 68/F
Central Plaza
18 Harbour Road
WanChai
Hong Kong
852 2230 3333
Fax 852 2230 3210