

NX Viewer

Powerful, easy-to-use viewer for sharing design and other information within NX

Benefits

- Because NX Viewer actually is NX, implementation and user interaction is instantly recognizable by NX users
- Presents a simplified, intuitive layout that enables even the casual user with no CAD experience to easily view and measure parts
- Provides the ability to accurately measure b-rep data for distance and mass properties
- Eliminates the problem of managing additional visualization files by using native NX data
- Ensures data integrity with "view-only" capability (no changes can be made)

Features

- With a wide array of viewing capabilities, wireframe and shaded displays, users can perform view operations such as fit, zoom, rotate and pan, as well as dynamic view sectioning and more
- Blanking and editing the display of objects (including translucency) enables the viewing of geometry contained inside enclosures

Summary

NX™ Viewer software is a cost-effective, simplified tool to view NX assembly, part and drawing data, accurately measure b-rep geometry and browse assemblies and model structures. It allows users to view native NX data, eliminating the need to manage additional data files. NX Viewer brings increased productivity through improved communication and understanding between groups.

Capabilities

NX Viewer is a cost-effective, simplified tool that enables the sharing of information between a company's various departments. It makes it easy for users to view NX assembly, part and drawing data, accurately measure b-rep geometry and browse assemblies and model structures. NX Viewer is a subset of NX with a simplified layout containing a reduced set of menu items and icons. It is the ideal tool for engineering managers, on the shop floor or in any other department that requires access to view assembly, part or drawing data, but do not desire or intend to save NX data.

Benefits

Traditionally, the use of a CAD system for reviewing engineering data required a design engineer to operate the CAD system, validate that the correct data was being viewed and ensure that changes were not inadvertently saved. While NX Viewer is powerful enough to meet the needs of

design and manufacturing engineers, it is easy enough to be used by people with little or no CAD experience. Using native NX data eliminates the need to manage additional data files, as required with "lightweight" viewers. Since no translation is involved, the user is confident in the data's integrity and the

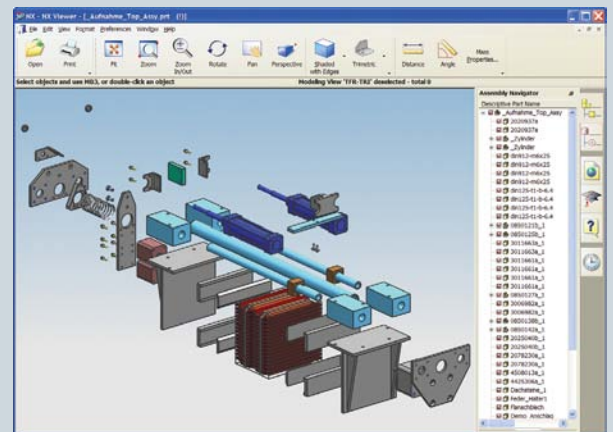

Manipulate view and display properties.

NX

www.siemens.com/nx

ACUITY
Your engineering technology partner

SIEMENS

NX Viewer

Features *continued*

- The product structure and feature trees can be explored with the assembly and model navigators. These navigators enable you to blank, isolate, open and close components
- Users are able to change between stored component reference sets
- Navigation between stored model views enables users to view product manufacturing information (PMI)

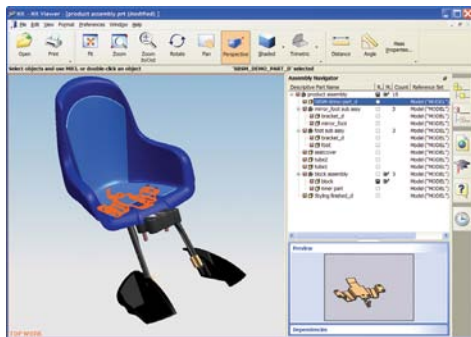

Navigate the assembly and model history tree.

accuracy of measurements. As a “view-only” tool, there is no risk that reviewers might accidentally change the design, thus keeping your data safe.

Customer value

Making design information accessible to departments outside engineering has tremendous benefits by improving communication and understanding between groups. This, in turn, improves productivity through the reduction of errors that result from miscommunication or misunderstanding. It should also be noted that companies will realize a reduction of costs based on the fact that corporate IT departments need only install, manage and support one system for the viewing of NX assembly, part and drawing data.

Reviewing engineering data using a CAD system requires a design engineer due to the complexity of operating the system as well as the need to protect the data from others inadvertently saving changes. NX Viewer is an ideal tool for engineering managers, on the shop floor or in any other department that requires access to view assembly, part or drawing data, but do not desire or intend to save or re-author NX data.

NX viewer is a cost-effective, simplified tool that enables the sharing of information between companies’ various departments. NX Viewer is a subset of NX with a simplified layout containing a reduced set of menu items and icons. NX Viewer is powerful enough to meet the needs of expert NX users such as design and manufacturing engineers, yet easy enough to use by people with no CAD experience.

Companies that have not yet implemented a data management solution will appreciate that NX Viewer is NX and does not require the management of separate file formats, as with “lightweight” CAD

viewers. There is no translation involved; when a user opens a part file, the user is working within NX with native files and can be confident in the data’s integrity and accuracy of measurements.

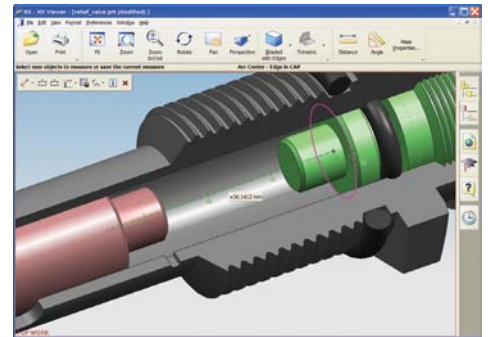

Accurate measurement of model geometry.

With NX Viewer, users can open and interrogate design information within NX parts, assemblies or drawings. NX Viewer supports both NX bookmarks and assembly load option views. Other viewing options include:

- Wireframe or shaded display
- View operations
 - Fit, zoom, rotate and pan
 - Dynamic view sectioning (to see internal structures, etc.)

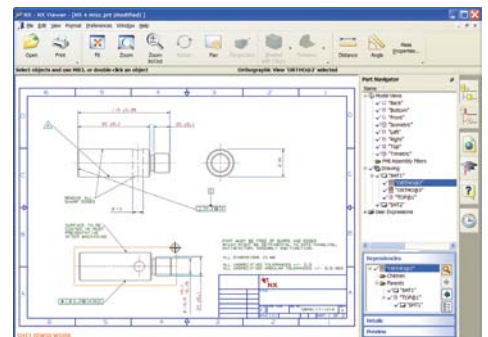

View and navigate drawing sheets.

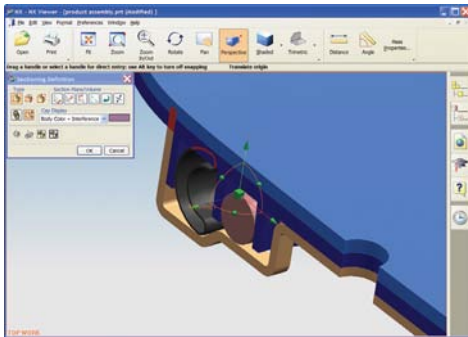

View sectioning to execute internal structures and interferences.

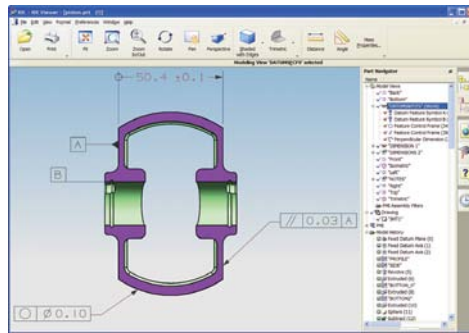

View 3D PMI annotation.

Product availability

NX Viewer is available as a standalone NX product beginning with NX 3.0.2. NX Viewer enables the user to open, view and measure NX assemblies, parts and drawings. NX Viewer is not a gateway to other NX applications (such as modeling, drafting, etc.)

- Blank, unblank, isolate and layer settings
- Edit object (such as translucency, capture screen shots, etc.)
- Assembly navigator
 - Navigate throughout the product structure or feature tree
 - Blank, isolate, open and close components
- Change reference sets
 - Show only solid geometry, show/don't show datum planes, etc.
- Model navigator
 - View models, including product manufacturing information (PMI)
 - View markup information
 - Understand how product was designed, step by step
 - Evaluate manufacturability
 - Measure tolerances
 - See feature dependencies and parameter details
 - Enable filters, blank and unblank
- View part, assembly and manufacturing drawings

ACUITY
Your engineering technology partner

www.acuityinc.com • info@acuityinc.com

Main Office: 7320 SW Hunziker Street, Suite 205 Tigard, OR 97223

Toll-free: 888.747.0850 • Direct: 503.747.0850 • Fax: 503.747.4269

© 2011 Siemens Product Lifecycle Management Software Inc. All rights reserved. Siemens and the Siemens logo are registered trademarks of Siemens AG. D-Cubed, Femap, Geolus, GO PLM, I-deas, Insight, JT, NX, Parasolid, Solid Edge, Teamcenter, Tecnomatix and Velocity Series are trademarks or registered trademarks of Siemens Product Lifecycle Management Software Inc. or its subsidiaries in the United States and in other countries. All other logos, trademarks, registered trademarks or service marks used herein are the property of their respective holders.
X3 7589 4/11 B